

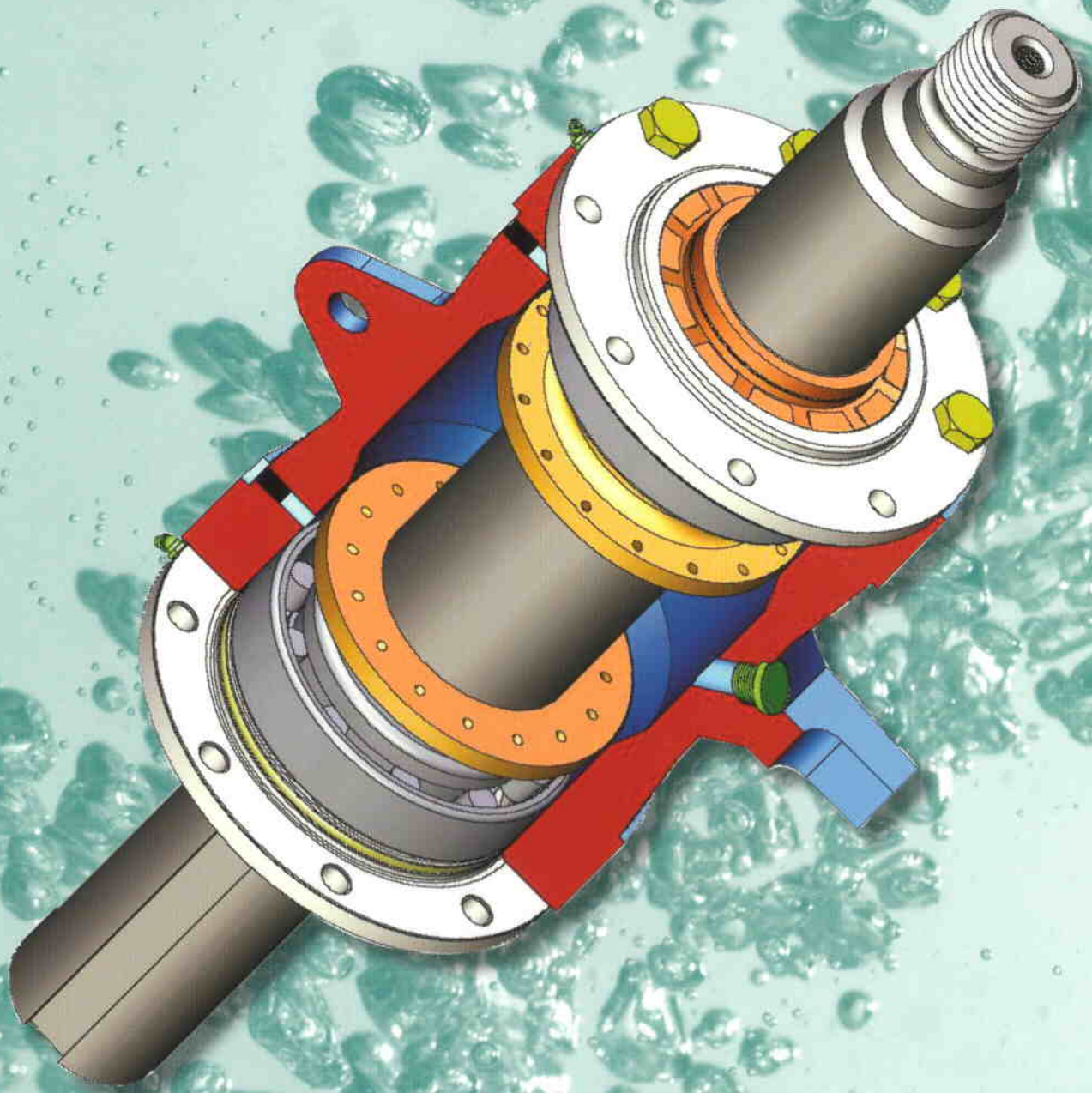

KETO Pumps International

Horizontal Bearing Assemblies



Upgrade performance & reliability

Improved Bearing Cartridge Reliability

The **KETO** range of slurry pumps offer improved reliability by use of patented designs and materials with the focus on reliability and total cost of ownership. The **KETO** bearing cartridge assembly offers many updated parts to improve on typical OEM failure points and allows increased life of the unit and reliable operation. **KETO** parts are interchangeable with certain OEM designs allowing you to upgrade without complex modification and costs.

Typical OEM Failure Points



It makes little sense to renew or replace bearing housing rotating parts to the same original specifications that allow it to fail or under perform in the first place?

Don't expect different results when using the same OEM ideas, parts and maintenance methods.

The Keto Alternative

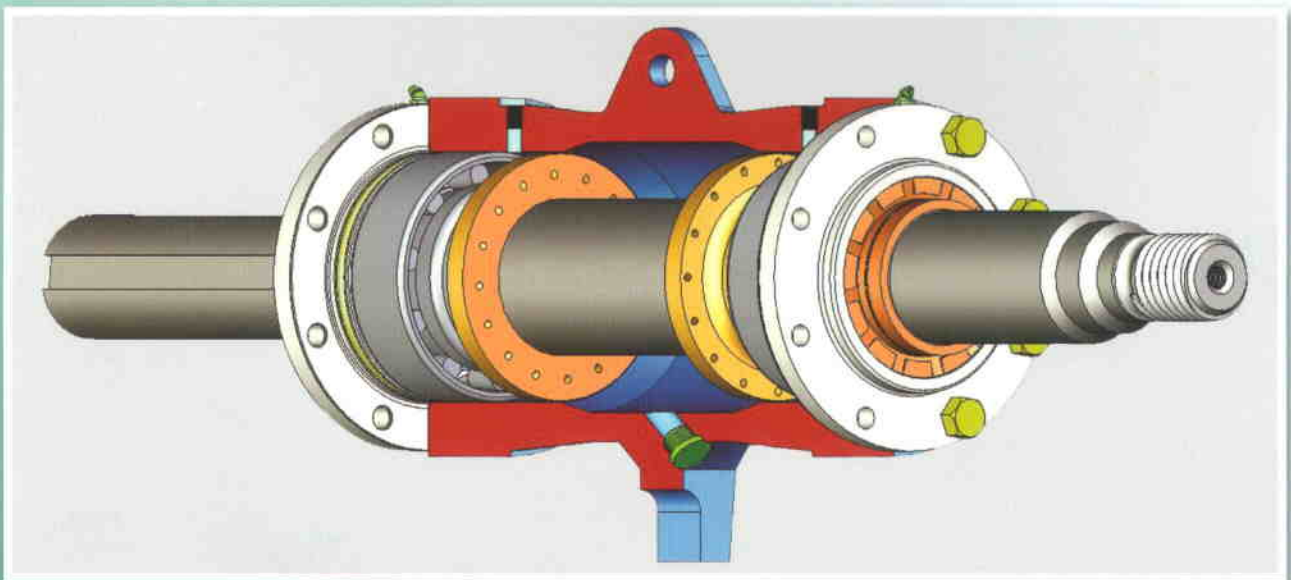

Features include:

- No need to grease daily!
- Direct upgrade on existing housings
- Longer service intervals/higher reliability
- Resists water entering bearing housing even under high pressure gland leakage
- Lower grease consumption/lower environmental impact
- Corrosion resistant alloys offered as standard with duplex alloy alternatives
- No piston rings to wear or break
- High quality grease can now be used as no labyrinth purge is used (unlike other OEM labyrinth designs)
- Available from smallest sizes to largest pumps
- End cover kits available for upgrading existing equipment
- Oil or grease lubrication possible without extensive modification

Bearing Housing Features

Contaminants are the number one enemy of bearings. According to studies, 70% of all bearing failures are due to the contaminants being entrained in the lubricant. **KETO KBAM Bearing Assemblies** do not risk entrainment of metal filings from piston rings in the lubricant, and our patented **KETO Labyrinth Bearing Isolator (KLBI)** is designed to stop any contaminants entering from outside.

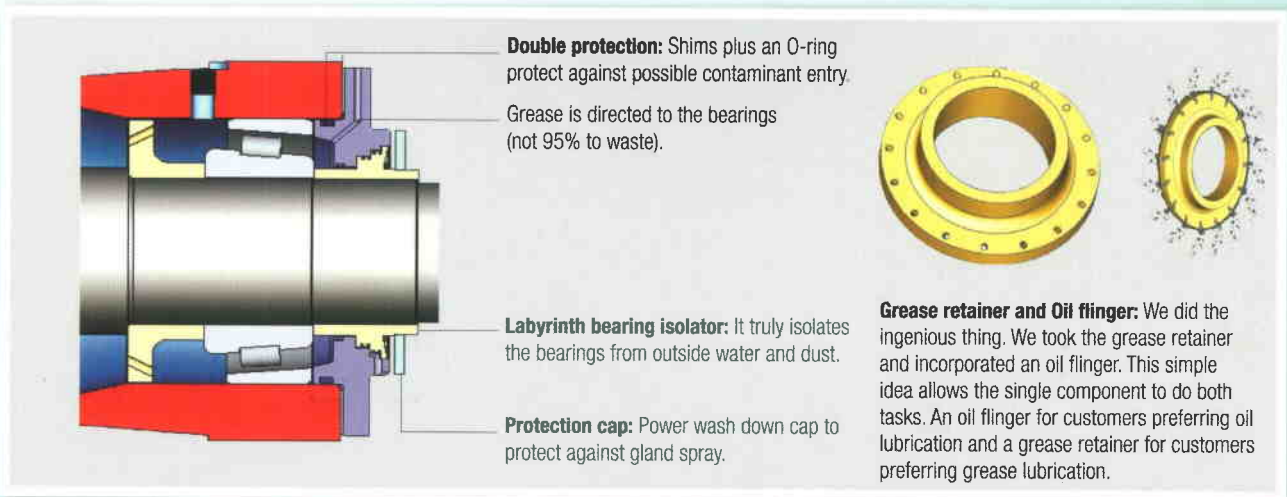
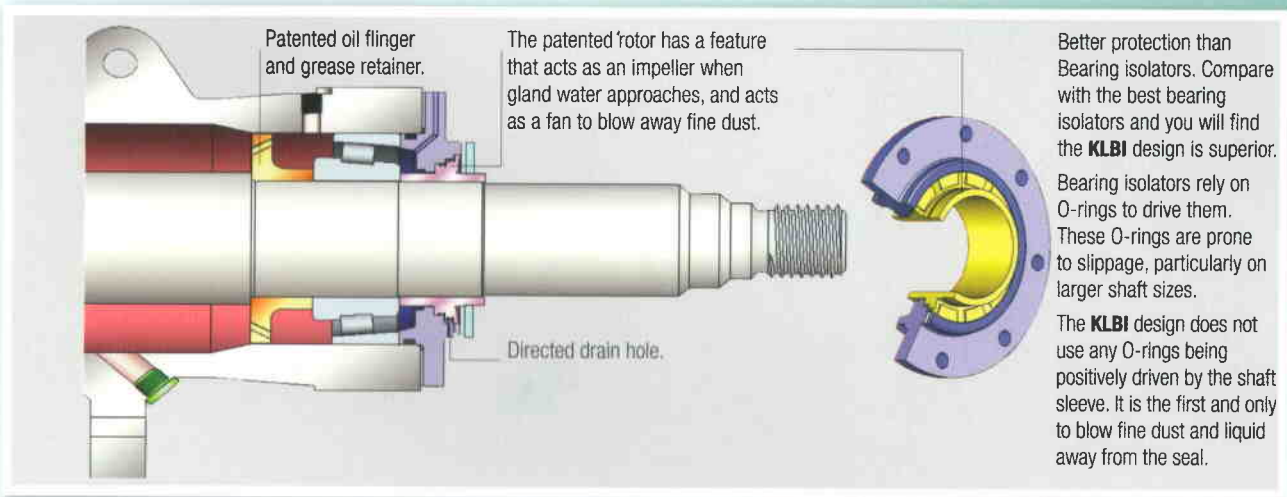
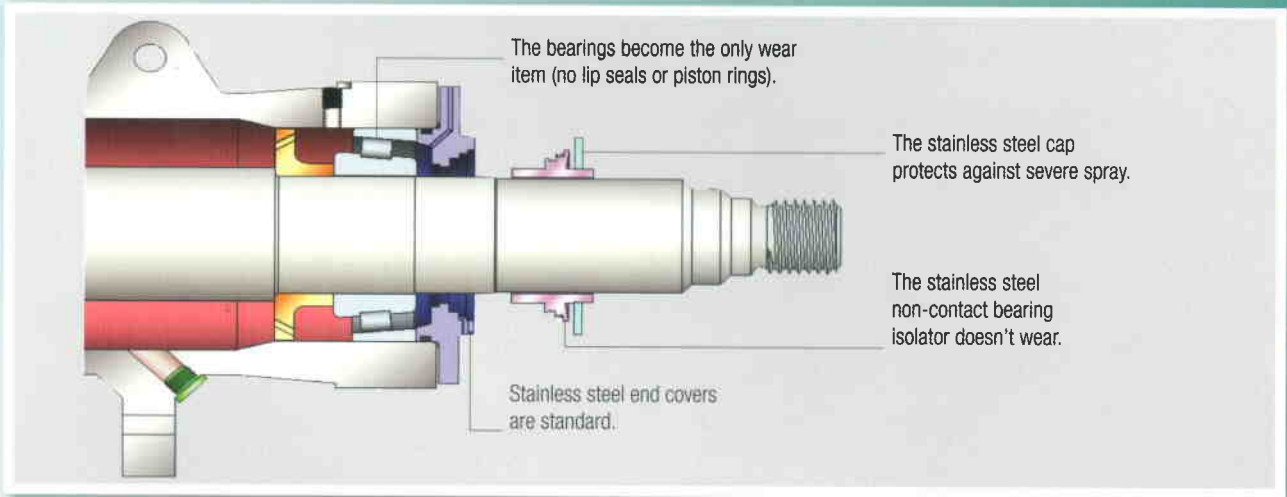



Grease or oil - your choice

Interested in upgrading your slurry Pumping to the next level in service and innovation?

Then contact:



KETO Pumps International

Tel: +61 8 9302 1440

Fax: +61 8 9302 1840

sales@ketopumps.com.au

1 Welsh Place, Landsdale, Western Australia 6065

PO Box 1119 Wangara, Western Australia 6947

ABN: 66 114 924 908

www.ketopumps.com.au